

## PRODUCT FEATURES

- IGBT CHIP(Trench+FS)
- High short circuit capability,self limiting short circuit current
- $V_{CE(sat)}$  with positive temperature coefficient
- Fast switching and short tail current
- Free wheeling diodes with fast and soft reverse recovery
- Temperature sense included

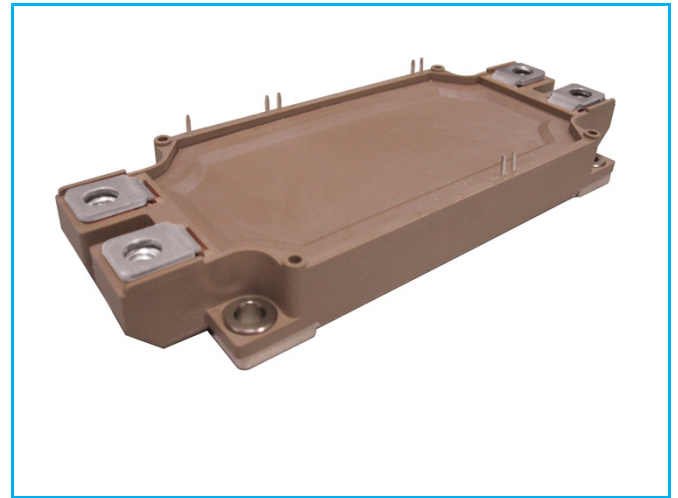

## APPLICATIONS

- AC motor control
- Motion/servo control
- Inverter and power supplies
- Photovoltaic/Fuel cell

### IGBT-inverter

ABSOLUTE MAXIMUM RATINGS( $T_C=25^{\circ}C$  unless otherwise specified)

| Symbol    | Parameter/Test Conditions         | Values                                   | Unit |
|-----------|-----------------------------------|--|------|
| $V_{CES}$ | Collector Emitter Voltage         | $T_J=25^{\circ}C$                        | V    |
| $V_{GES}$ | Gate Emitter Voltage              |  |      |
| $I_C$     | DC Collector Current              | $T_C=25^{\circ}C, T_{Jmax}=175^{\circ}C$ | 690  |
|           |                                   | $T_C=55^{\circ}C, T_{Jmax}=175^{\circ}C$ | 600  |
| $I_{CM}$  | Repetitive Peak Collector Current | $t_p=1ms$                                | 1200 |
| $P_{tot}$ | Power Dissipation Per IGBT        | $T_C=25^{\circ}C, T_{Jmax}=175^{\circ}C$ | 1760 |
|           |                                   |  | W    |

### Diode-inverter

ABSOLUTE MAXIMUM RATINGS ( $T_C=25^{\circ}C$  unless otherwise specified)

| Symbol      | Parameter/Test Conditions       | Values                             | Unit    |
|-------------|---------------------------------|------------------------------------|---------|
| $V_{RRM}$   | Repetitive Reverse Voltage      | $T_J=25^{\circ}C$                  | V       |
| $I_{F(AV)}$ | Average Forward Current         |                                    | A       |
| $I_{FRM}$   | Repetitive Peak Forward Current | $t_p=1ms$                          |         |
| $I^2t$      |                                 | $T_J=125^{\circ}C, t=10ms, V_R=0V$ | $kA^2s$ |

MacMic Science & Technology Co., Ltd.

Add: #18, Hua Shan Zhong Lu, New District, Changzhou City, Jiangsu Province, P. R. of China

# MMG600WB065B6TC

## IGBT-inverter

### ELECTRICAL CHARACTERISTICS ( $T_C=25^\circ\text{C}$ unless otherwise specified)

| Symbol        | Parameter/Test Conditions                        |  | Min.                    | Typ. | Max.  | Unit          |
|---------------|--|--|-------------------------|------|-------|---------------|
| $V_{GE(th)}$  | Gate Emitter Threshold Voltage                   | $V_{CE}=V_{GE}, I_C=9.6\text{mA}$  | 5.0                     | 6.0  | 6.5   | V             |
| $V_{CE(sat)}$ | Collector Emitter Saturation Voltage             | $I_C=600\text{A}, V_{GE}=15\text{V}, T_J=25^\circ\text{C}$                                   |                         | 1.55 | 2.0   |               |
|               |  | $I_C=600\text{A}, V_{GE}=15\text{V}, T_J=125^\circ\text{C}$                                  |                         | 1.75 |       |               |
|               |  | $I_C=600\text{A}, V_{GE}=15\text{V}, T_J=150^\circ\text{C}$                                  |                         | 1.8  |       |               |
| $I_{CES}$     | Collector Leakage Current                        | $V_{CE}=650\text{V}, V_{GE}=0\text{V}, T_J=25^\circ\text{C}$                                 |                         |      | 3     | mA            |
|               |  | $V_{CE}=650\text{V}, V_{GE}=0\text{V}, T_J=150^\circ\text{C}$                                |                         |      | 15    | mA            |
| $I_{GES}$     | Gate Leakage Current                             | $V_{CE}=0\text{V}, V_{GE}=\pm 20\text{V}, T_J=25^\circ\text{C}$                              | -500                    |      | 500   | nA            |
| $R_{Gint}$    | Integrated Gate Resistor                         |  |                         | 0.5  |       | $\Omega$      |
| $Q_g$         | Gate Charge                                      | $V_{CE}=300\text{V}, I_C=600\text{A}, V_{GE}=15\text{V}$                                     |                         | 3.3  |       | $\mu\text{C}$ |
| $C_{ies}$     | Input Capacitance                                | $V_{CE}=25\text{V}, V_{GE}=0\text{V}, f=1\text{MHz}$   |                         | 39   |       | nF            |
| $C_{res}$     | Reverse Transfer Capacitance                     |  |                         |      | 1.3   |               |
| $t_{d(on)}$   | Turn on Delay Time                               | $V_{CC}=300\text{V}, I_C=600\text{A}$<br>$R_G=1.5\Omega,$                                    | $T_J=25^\circ\text{C}$  |      | 80    | ns            |
|               |  |  | $T_J=150^\circ\text{C}$ |      | 90    | ns            |
| $t_r$         | Rise Time  | $V_{GE}=\pm 15\text{V},$<br>Inductive Load   | $T_J=25^\circ\text{C}$  |      | 130   | ns            |
|               |  |  | $T_J=150^\circ\text{C}$ |      | 140   | ns            |
| $t_{d(off)}$  | Turn off Delay Time                              | $V_{CC}=300\text{V}, I_C=600\text{A}$<br>$R_G=1.5\Omega,$                                    | $T_J=25^\circ\text{C}$  |      | 480   | ns            |
|               |  |  | $T_J=150^\circ\text{C}$ |      | 520   | ns            |
| $t_f$         | Fall Time  | $V_{GE}=\pm 15\text{V},$<br>Inductive Load   | $T_J=25^\circ\text{C}$  |      | 80    | ns            |
|               |  |  | $T_J=150^\circ\text{C}$ |      | 100   | ns            |
| $E_{on}$      | Turn on Energy                                   | $V_{CC}=300\text{V}, I_C=600\text{A}$<br>$R_G=1.5\Omega,$                                    | $T_J=25^\circ\text{C}$  |      | 17.6  | mJ            |
|               |  |  | $T_J=150^\circ\text{C}$ |      | 24    | mJ            |
| $E_{off}$     | Turn off Energy                                  | $V_{GE}=\pm 15\text{V},$<br>Inductive Load   | $T_J=25^\circ\text{C}$  |      | 23.5  | mJ            |
|               |  |  | $T_J=150^\circ\text{C}$ |      | 30.5  | mJ            |
| $I_{SC}$      | Short Circuit Current                            | $tp_{sc}\leq 6\mu\text{s}, V_{GE}=15\text{V}$<br>$T_J=150^\circ\text{C}, V_{CC}=360\text{V}$ |                         | 3000 |       | A             |
| $R_{thJC}$    | Junction to Case Thermal Resistance ( Per IGBT ) |  |                         |      | 0.085 | K /W          |

## Diode-inverter

### ELECTRICAL CHARACTERISTICS ( $T_C=25^\circ\text{C}$ unless otherwise specified)

| Symbol      | Parameter/Test Conditions                         |  | Min. | Typ. | Max. | Unit          |
|-------------|---|--|------|------|------|---------------|
| $V_F$       | Forward Voltage                                   | $I_F=600\text{A}, V_{GE}=0\text{V}, T_J=25^\circ\text{C}$  |      | 1.7  | 2.1  | V             |
|             |   | $I_F=600\text{A}, V_{GE}=0\text{V}, T_J=125^\circ\text{C}$   |      | 1.55 |      |               |
|             |   | $I_F=600\text{A}, V_{GE}=0\text{V}, T_J=150^\circ\text{C}$   |      | 1.45 |      |               |
| $t_{rr}$    | Reverse Recovery Time                             | $I_F=600\text{A}, V_R=300\text{V}$<br>$di_F/dt=-4500\text{A}/\mu\text{s}$<br>$T_J=150^\circ\text{C}$ |      | 280  |      | ns            |
| $I_{RRM}$   | Max. Reverse Recovery Current                     |  |      | 295  |      | A             |
| $Q_{RR}$    | Reverse Recovery Charge                           |  |      | 45   |      | $\mu\text{C}$ |
| $E_{rec}$   | Reverse Recovery Energy                           |  |      | 12   |      | mJ            |
| $R_{thJCD}$ | Junction to Case Thermal Resistance ( Per Diode ) |  |      |      | 0.15 | K /W          |

# MMG600WB065B6TC

## NTC CHARACTERISTICS ( $T_C=25^\circ\text{C}$ unless otherwise specified)

| Symbol      | Parameter/Test Conditions                                     | Min. | Typ. | Max. | Unit       |
|-------------|---|------|------|------|------------|
| $R_{25}$    | Resistance $T_C=25^\circ\text{C}$                             |      | 5    |      | k $\Omega$ |
| $B_{25/50}$ | $R_2 = R_{25} \exp [B_{25/50}(1/T_2 - 1/(298.15 \text{ K}))]$ |      | 3375 |      | K          |

## MODULE CHARACTERISTICS ( $T_C=25^\circ\text{C}$ unless otherwise specified)

| Symbol     | Parameter/Test Conditions   | Values                     | Unit             |    |
|------------|-----------------------------|----------------------------|------------------|----|
| $T_{Jmax}$ | Max. Junction Temperature   | 175                        | $^\circ\text{C}$ |    |
| $T_{Jop}$  | Operating Temperature       | -40~150                    |                  |    |
| $T_{stg}$  | Storage Temperature         | -40~125                    |                  |    |
| $V_{isol}$ | Isolation Breakdown Voltage | AC, 50Hz(R.M.S), t=1minute | 3000             | V  |
| CTI        | Comparative Tracking Index  |                            | > 200            |    |
| Torque     | to heatsink                 | Recommended (M5)           | 2.5~5            | Nm |
|            | to terminal                 | Recommended (M6)           | 3~5              | Nm |
| Weight     |                             |                            | 350              | g  |

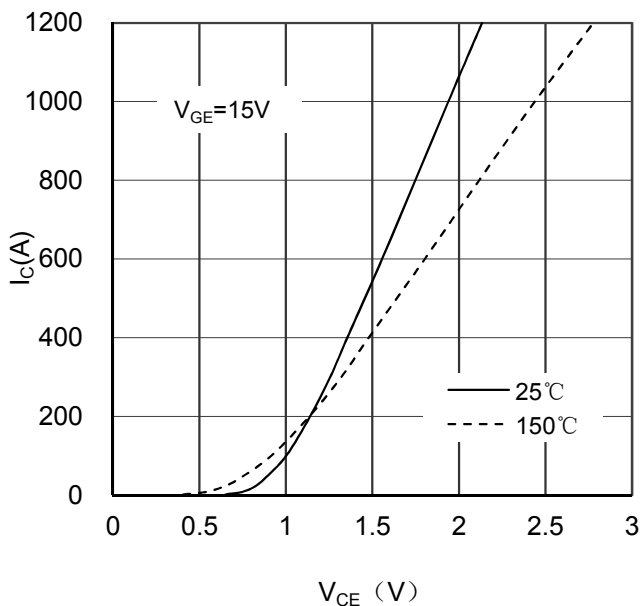

Figure 1. Typical Output Characteristics IGBT-inverter

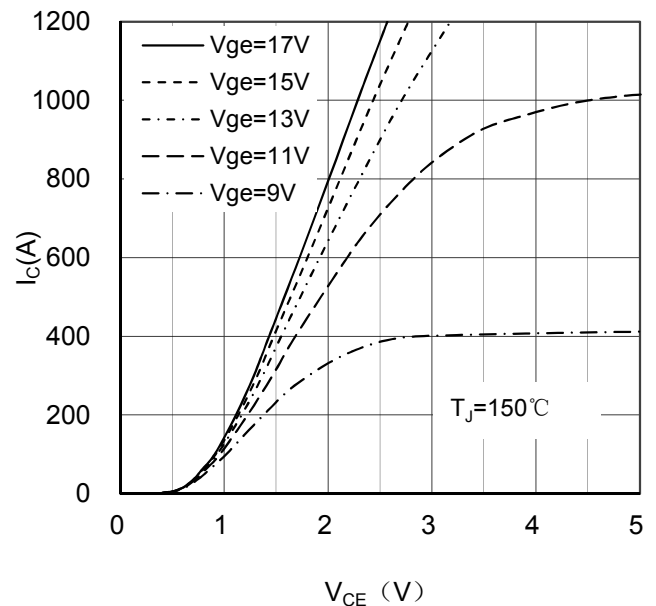

Figure 2. Typical Output Characteristics IGBT-inverter

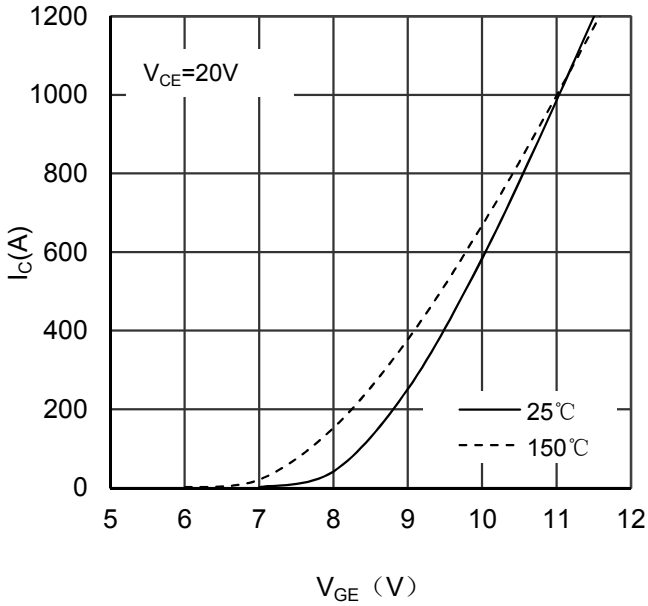

Figure 3. Typical Transfer characteristics IGBT-inverter

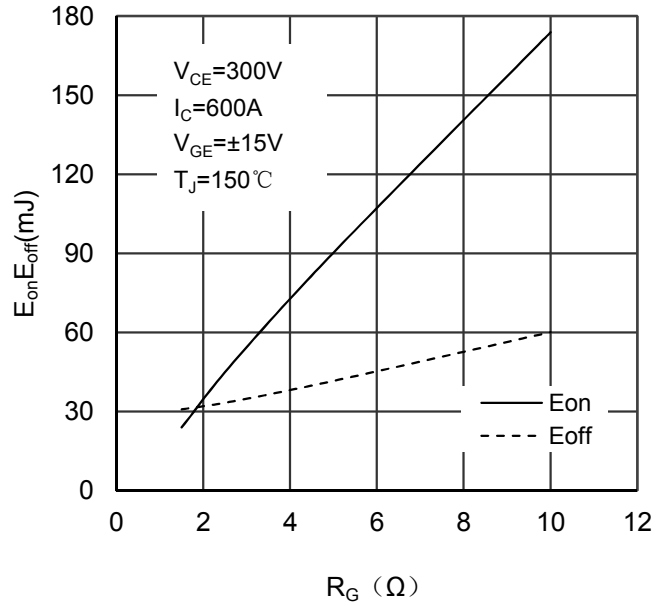

Figure 4. Switching Energy vs Gate Resistor IGBT-inverter

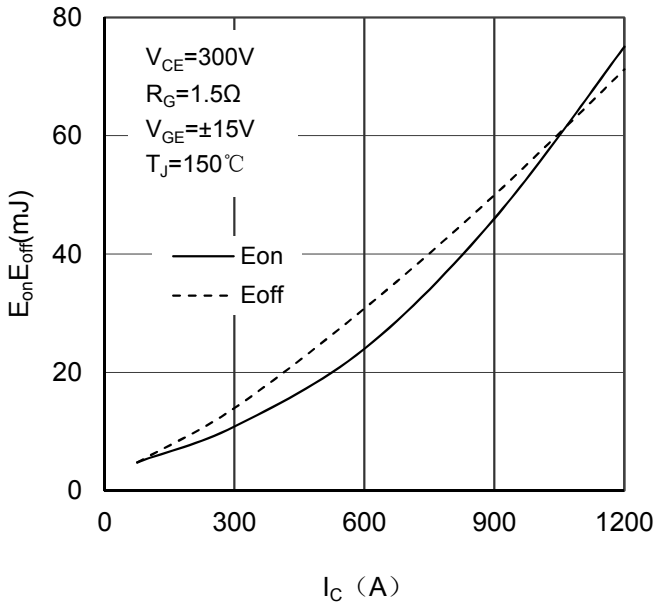

Figure 5. Switching Energy vs Collector Current IGBT-inverter

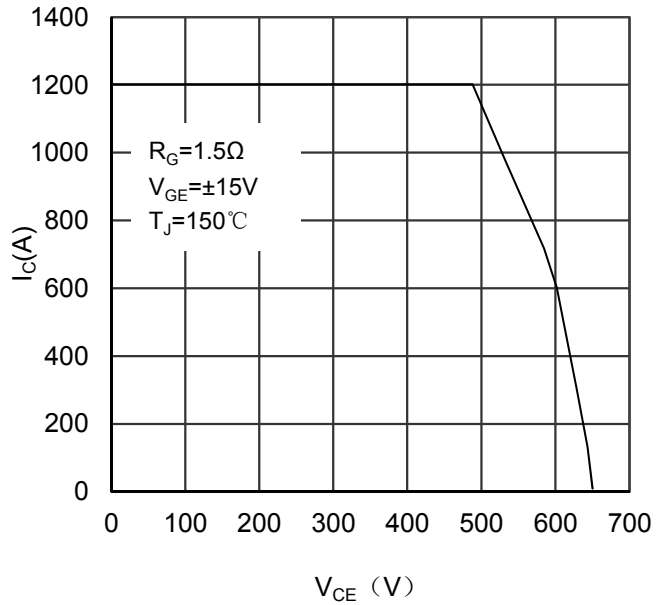

Figure 6. Reverse Biased Safe Operating Area IGBT-inverter

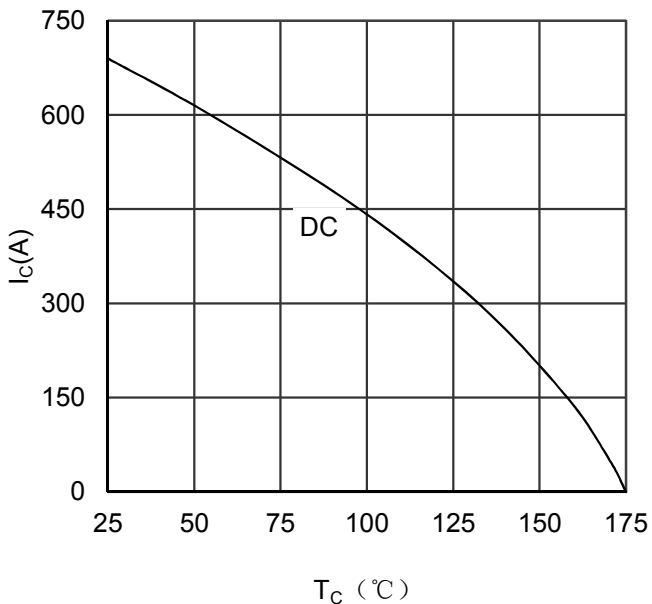

Figure 7. Collector Current vs Case temperature IGBT-inverter

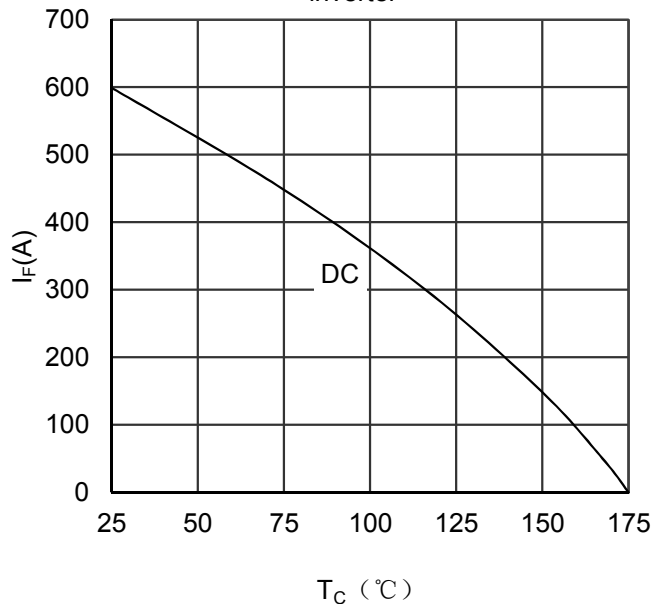

Figure 8. Forward current vs Case temperature Diode-inverter

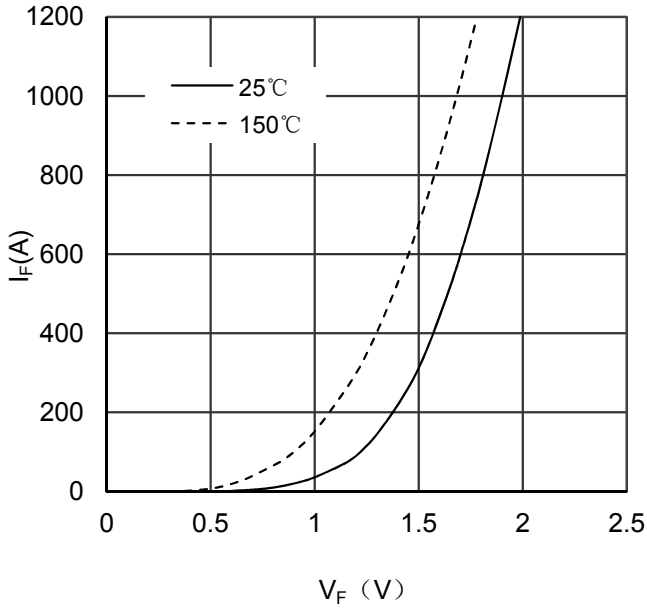

Figure 9. Diode Forward Characteristics Diode -inverter

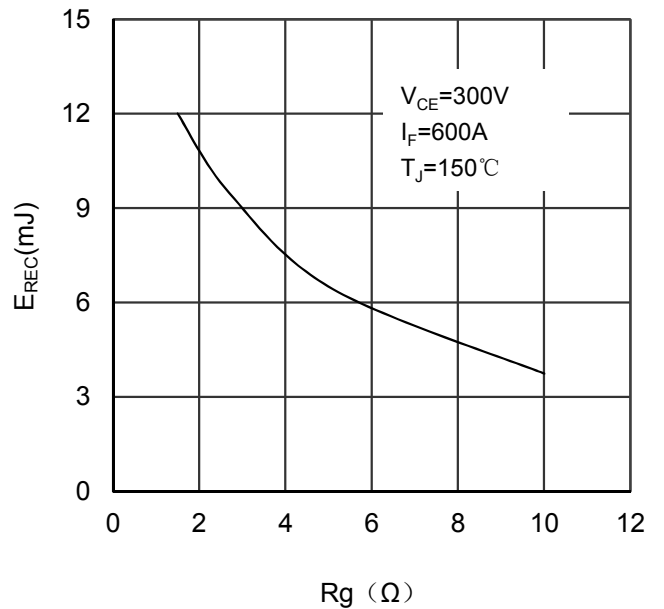

Figure 10. Switching Energy vs Gate Resistor Diode - inverter

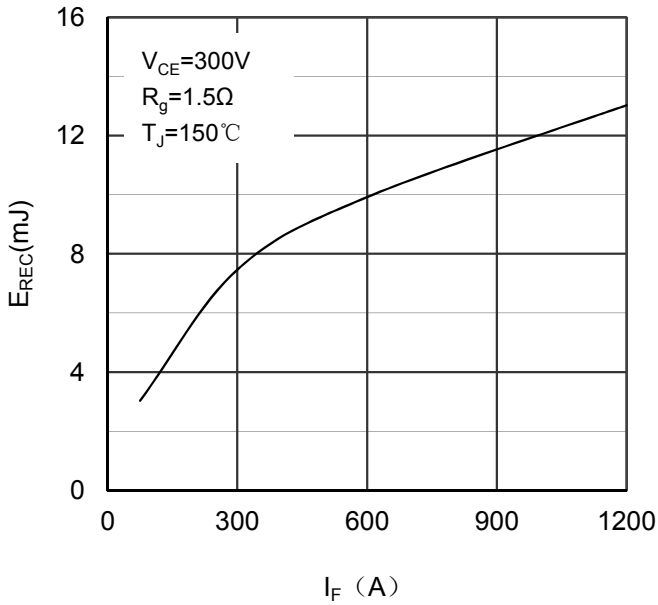

Figure 11. Switching Energy vs Forward Current Diode-inverter

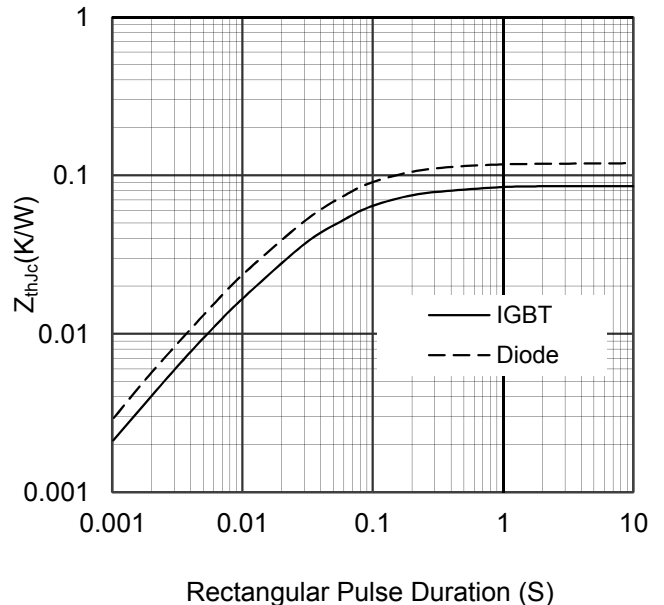

Figure 12. Transient Thermal Impedance of Diode and IGBT-inverter

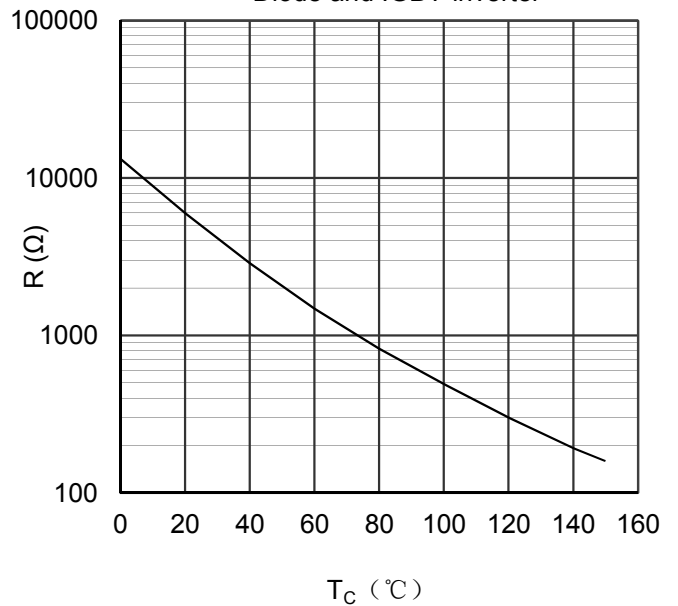

Figure 13. NTC Characteristics

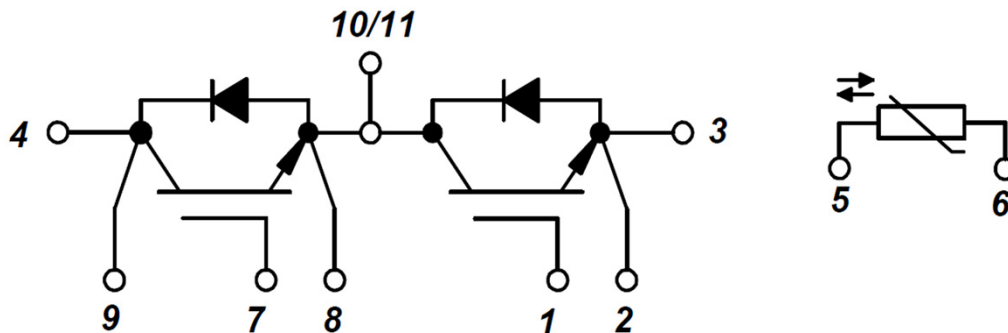
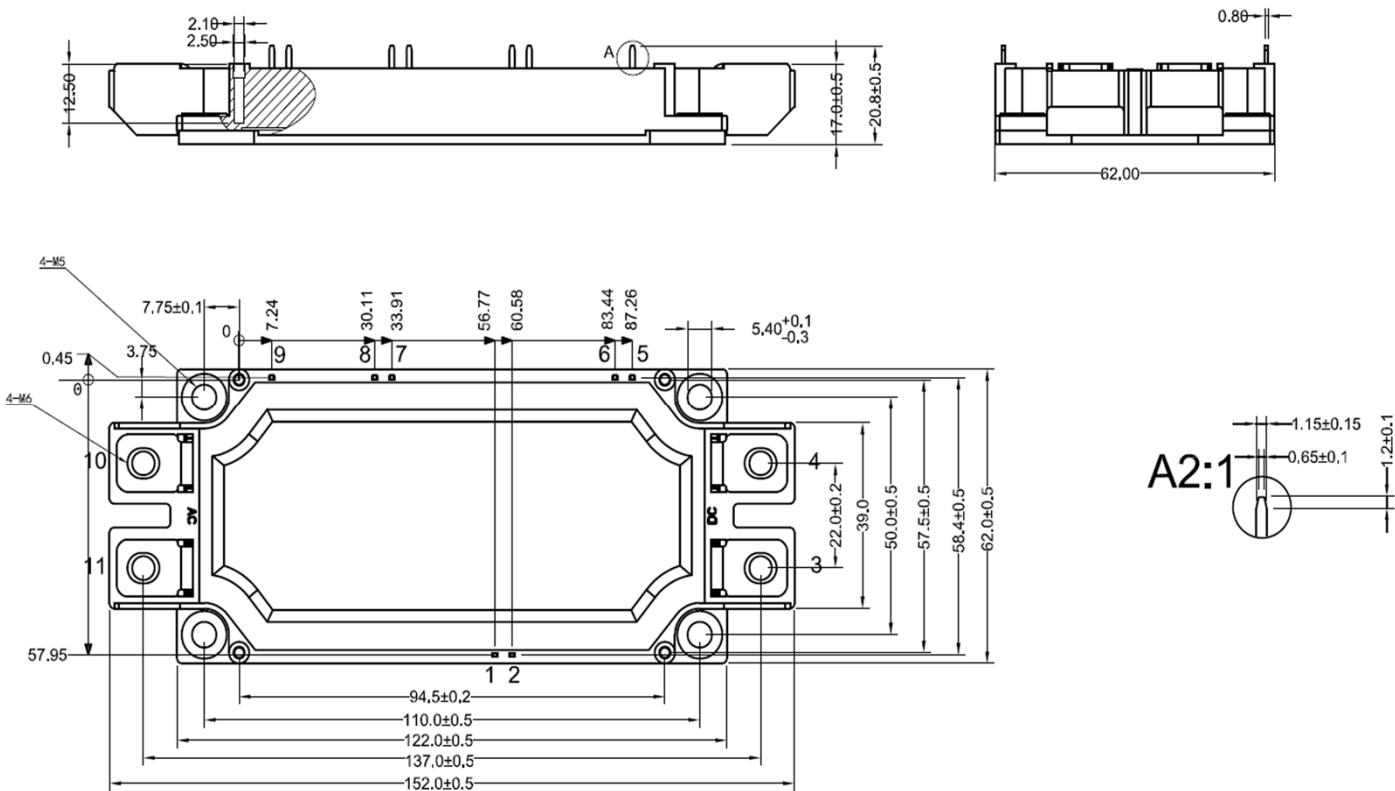

Figure 14. Circuit Diagram



Dimensions in (mm)

Figure 15. Package Outline